

DG Flugzeugbau GmbH

Otto-Lilienthal-Weg 2 / Am Flugplatz • D-76646 Bruchsal • Germany

Postbox 1480, D-76604 Bruchsal • Germany

Tel. 07251 3020-100 • Telefax 07251 3020-200 • eMail: dg@dg-flugzeugbau.de

Spare part and material sales: Tel. 07251 3020-270 • lager@dg-flugzeugbau.de

www.dg-flugzeugbau.de

Manual for the emergency bail out aid NOAH

for DG-single seaters with single piece canopies

NOAH airbag manufacturer bfa

Issued: June 2002

Manual for the emergency bail out aid NOAH for DG-single seaters with single piece canopies

Record of revisions

Any revision of the present manual, except actual weighing data, must be recorded in the following table and in case of approved sections endorsed by the responsible airworthiness authority.

The new or amended text in the revised page will be indicated by a black vertical line in the right hand margin, and the Revision No. and the date will be shown on the bottom left hand of the page.

Rev. No.	Affected Pages	Description	Issue Date
1 + 2		Only for new type NOAH airbag (manufacturer cartrim)	
3	3, 8, 10, 11, enclosure 1, Z108	Correction safety wire, List for annual weight measurement NOAH refilling instructions	April 2008

Manual for the emergency bail out aid NOAH for DG-single seaters with single piece canopies

Content

1. Description of the NOAH-system
2. Operating instructions NOAH
3. Maintenance instructions
 - 3.1 Annual inspection and service
 - 3.2 Service every 10 years
 - 3.3 Installation of the NOAH system
 - 3.4 Installation and removal of the pressurised gas cylinder for inspection
 - 3.5 Disconnecting the airbag from the pressure hose
 - 3.6 Filling the airbag for inspection purposes
 - 3.7 Folding and attaching the airbag
 - 3.8 Replacing Bowden-cables
 - 3.9 Seat harness buckle
 - 3.10 Life time of the NOAH components / spare part list
 - 3.11 Sending in for maintenance
4. List of tools
5. Materials for maintenance
6. Appendix
 - 6.1 List for annual weight measurement
 - 6.2 Drawings

NOAH general	Z92
Folding the airbag	Z99
pressurised gas cylinder with securing system	Z108
 - 6.3 Enclosure 1: NOAH refilling instructions

Manual for the emergency bail out aid NOAH for DG-single seaters with single piece canopies

1. Description of the NOAH-system

NOAH is a system to facilitate the bail out of the cockpit in an emergency. NOAH is a supplementation to the parachute.

NOAH features an airbag similar to a car airbag. The gas which is necessary to inflate the bag is stored in a pressurised gas cylinder. The actuation is by mechanical means via a handle at the right hand side near the control stick. To actuate NOAH the canopy must be opened or jettisoned first. The system is secured by a metal plate at the actuation unit which is blocked by a GFRP block at the canopy frame. The actuation handle is marked black and yellow.

A sticker is wrapped around the actuation handle and the guiding tube for the actuation cable. The sticker serves as an additional means to guard against inadvertent operation.



When the NOAH system is activated the seat harness buckle will be opened prior to the opening of the pressurised gas cylinder. The pilot will be lifted by the airbag so that he can roll himself out of the cockpit.

If NOAH is used together with an automatic parachute, the emergency bail out procedure will be more or less automatic after operation of the NOAH handle.

Note: There is a small hole in the NOAH airbag close to the pressure relief valve. In case of inadvertent inflation of the airbag gas can stream out of this hole. This is to prevent injuries to the pilot if the seat harness buckle is not open.

Technical data:

Mass of all parts: approx. 4,5 kg

Generation of pressure: nitrogen approx. 200 bar

Filling time: approx. 2 seconds

Design range: pilot mass 110 kg up to 4 g

General design see drawing Z92

Manual for the emergency bail out aid NOAH for DG-single seaters with single piece canopies

2. Operating instructions NOAH

a) Pre-flight inspection

Check the airbag, the high pressure hose and the operating cables for correct positioning and for any wear.

Check especially if the nipple of the cable which opens the seat harness buckle is positioned aft of the cam of the actuation unit see sketch:

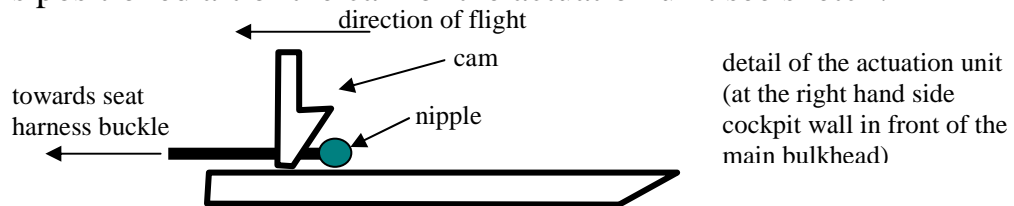

b) Use of NOAH in case of an emergency bail out:

Note: We recommend strongly the use of an automatic parachute. Only with an automatic parachute will the bail out procedure be nearly automatic and precious time and altitude can be saved.

For the bail out jettison the canopy first, therefore pull the canopy emergency release and if necessary push the canopy upwards.

Warning: If there are loops at the rudder pedals make sure that your feet are out of the loops first.

Then pull the NOAH handle (at the right hand side next to the control stick, marked black and yellow) **strongly and quickly** up to its stop.

Roll out of the cockpit to the right hand side if possible, as on the left hand side the airbrake handle may impede the procedure.

Note: Don't operate the NOAH handle on the ground with open canopy as you may release NOAH and the pressurised gas cylinder must be filled again.

Note: For normal opening of the seat harness buckle rotate the buckle only in clockwise direction.

Manual for the emergency bail out aid NOAH for DG-single seaters with single piece canopies

3. Maintenance instructions

3.1 Annual inspection and service:

1. Check if the pressurised gas cylinder is full: To accomplish this remove the cylinder from the glider see sect. 3.4 and weigh the cylinder. Compare the weight with the data on the placard on the cylinder. The balance must measure with a precision of 1g. If the weight is max. 5g lower than the data on the placard, the cylinder must be sent in for refilling.
Enter weight, date and inspection signature into the placard.
2. Check if the safety wire (item F on sketch in section 3.4) is damaged. If the wire is damaged, the cylinder must be sent in for maintenance.
3. Visually check all parts assembled to the pressurised gas cylinder.
4. Visually check the airbag and the high pressure hose for any wear. Remove the cover of the airbag for this check.
5. Check the airbag for tightness see section 3.6.
6. Visually check all Bowden cables and the actuation unit for any wear and for corrosion.
7. Function check of the actuation unit (cylinder removed): Pull out the NOAH handle slowly and check the following items:
 - a) The seat harness buckle must fully release the seat harness approx. 10mm before the nipple of the Bowden-cable (running to the buckle) is inserted in the groove of the actuation unit see sketch.

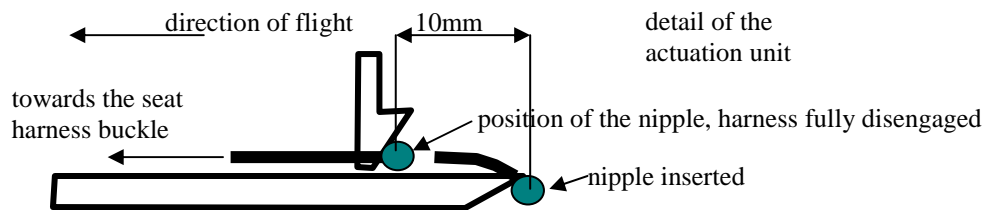

- b) The nipple of the Bowden cable must be inserted in the groove of the actuation unit before the seat harness buckle comes to its stop. The cable which runs to the pressurised gas cylinder shall not be tightened but have approx. 10mm freeplay (clevis pin in the slotted hole of the actuation unit).
- c) Move the cam of the actuation unit back to its initial position and release the nipple, the seat harness buckle must move back or must be turned back to its locked position.

Make sure that the nipple is positioned behind the cam, see sketch.

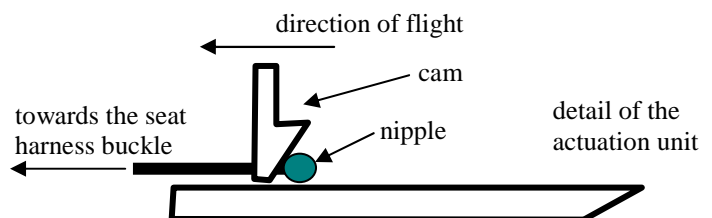

Manual for the emergency bail out aid NOAH for DG-single seaters with single piece canopies

8. Maintenance: All parts are maintenance free and it is not allowed to oil or grease any part.
9. Assembly is in reverse order to removal. Fold the airbag according to section 3.7.
10. Use a new sticker and wrap it symmetrically around the handle and over the guiding tube of the operating cable. Press together both halves of the placard so that they stick together and to the guiding tube. The sticker serves as an additional means to prevent from inadvertent operation.



3.2 Maintenance every ten years

1. After 10 years the NOAH airbag and the high pressure hose have reached their lifetime. The pressurised gas cylinder must be inspected by a technical organisation approved for such inspections. As the pressurised gas cylinder must be emptied for this inspection you should use this opportunity for a complete test of your NOAH system.
2. Test: Buckle your seat harness, canopy open. Pull the NOAH operating handle **strongly and quickly** up to its stop. After the seat harness has opened the airbag should blow up in approx. 2 seconds.
3. To remove the gas from the airbag pull off the high pressure hose.
4. Remove the pressurised gas cylinder (see sect. 3.4), send in for inspection and refilling see sect. 3.11.
5. When you get the cylinder back install it together with the new airbag and high pressure hose. Execute items 2 and 4 up to 10 of the annual inspection see section 3.1. Enter the new parts in the record of life limited components of your glider.

3.3 Installation of the NOAH system

Install the system according to the installation instructions which belong to the technical note concerning the installation of the NOAH system into your glider type.

Enter the NOAH airbag, the high pressure hose and the pressurised gas cylinder into the record of life limited components of your glider.

Manual for the emergency bail out aid NOAH for DG-single seaters with single piece canopies

3.4 Installation and removal of the pressurised gas cylinder for inspection

1. Remove the GFRP tube for the oxygen cylinder and the access cover in front of this tube.

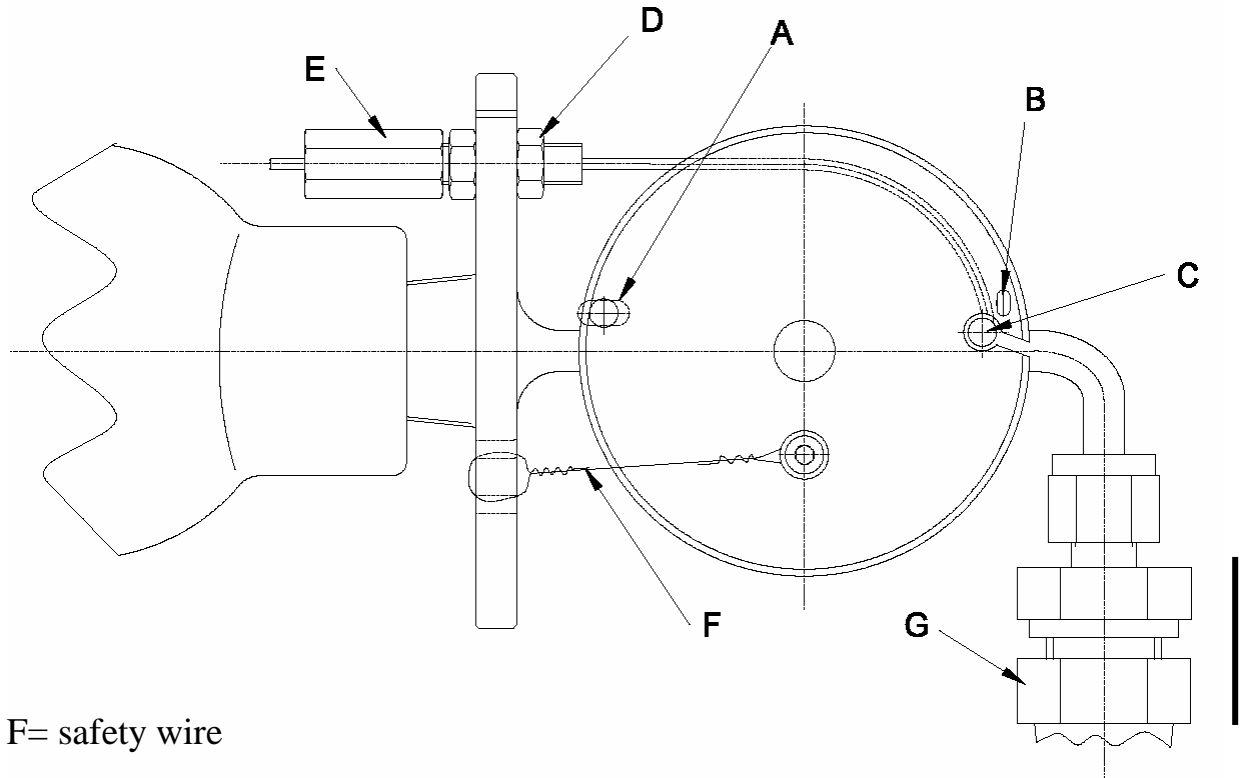

F= safety wire

2. Install the transport securing device A (split pin 4x28 DIN94 St), insert into the hole and split up a little.
3. Remove the Bowden cable. Therefore remove the split pin B (split pin 2x20 DIN 94 St) so that the nipple C can be taken out of the operating disc. Then unfasten nut D and take out the adjustment screw E.
4. Remove the high pressure hose from the pressurised gas cylinder. Therefore unfasten the cap nut G (at the hose). (2 22mm open end spanners are needed).
5. Open completely the hose clamp which holds the cylinder down (7mm socket wrench) and pull out the cylinder.
6. Assembly is the reverse of removal. Remove the transport securing device A when the system is completely installed.

3.5 Removal of the high pressure hose from the airbag

Pull out the U-shaped wire clip using universal pliers. Pull off the fitting from the airbag.

Manual for the emergency bail out aid NOAH for DG-single seaters with single piece canopies

3.6 Filling the airbag for inspection purpose

Close the small hole (in the front of the airbag next to the pressure relief valve) with tape. Fill the airbag via the high pressure hose. This must be done with a pressure air system which is equipped with a pressure reducer, a control valve and with a manometer (measuring range 0-0.5 bar).

To check the airbag for tightness and simultaneously the pressure relief valve proceed as follows: Fill the airbag slowly, press onto the small hole with your finger in addition to the tape. Note at which pressure you can hear the air starting to flow out of the bag. The opening pressure of the pressure relief valve should be 0,33-0,43 bar. If this is not the case, the valve insert must be replaced.

Remove the tape from the hole.

3.7 Folding and attaching the airbag

Fix the airbag with Velcro strips to the seat shell. Then fold the airbag according to drawing Z99 and fix the cover with Velcro strips.

3.8 Replacement of Bowden cables

When replacing Bowden cables be sure to adjust the cables so that the correct sequence of all functions is ensured according to section 3.1 item 7..

Manual for the emergency bail out aid NOAH for DG-single seaters with single piece canopies

3.9 Seat harness buckle

If the NOAH airbag has been inflated with the seat harness not opened, the seat harness buckle can be damaged. After such incidence the complete harness must be removed prior to the next flight and sent to its manufacturer for inspection and repair.

3.10 Life time of the NOAH components / spare part list

The NOAH airbag has a lifetime of 10 years. If the airbag was inflated in an emergency or inadvertently via the pressurised gas cylinder, the airbag must be replaced.

part-/drawing no.	description	life time
10533-100	NOAH-airbag.	10 years
10533-200	cover for airbag.	unlimited**
10533-130	inserts for pressure relief valve	unlimited**
10533-131	sealing ring for pressure relief valve	10 years
10533-120	inlet valve	unlimited**
10533-310	high pressure hose	10 years
Z108	pressurised gas cylinder with valve	unlimited ** inspection of the cylinder (every 10 years) according to TRG
Z80	NOAH actuation unit	unlimited**

** if no damage or excessive wear can be detected

3.11 Sending in for maintenance

Maintenance station:

DG-Flugzeugbau
Otto-Lilienthal-Weg 2
D 76646 Bruchsal
Germany

Refilling the NOAH pressurised gas cylinder or exchange of the safety wire:

For such work the NOAH pressurised gas cylinder must not be shipped to the Maintenance station. You may proceed according to enclosure 1 "NOAH refilling instructions"

**Manual for the emergency bail out aid NOAH
for DG-single seaters with single piece canopies**

4. List of tools

1. universal pliers
2. open end spanners 10mm, 2 pieces 22mm
3. socket wrench 7mm with extension
4. screw driver
5. spanner 34mm (for pressure relief valve)

5. Materials for maintenance

- split pin 2x20 DIN94 St (securing of the Bowden cable)
- split pin 4x28 DIN94 St (transport securing)

6. Appendix

6.1. List for annual weight measurement

	Date	Weight of bottle	Inspection signature
1			
2			
3			
4			
5			
6			
7			
8			
9			
10			
11			
12			
13			
14			
15			
16			
17			
18			
19			
20			

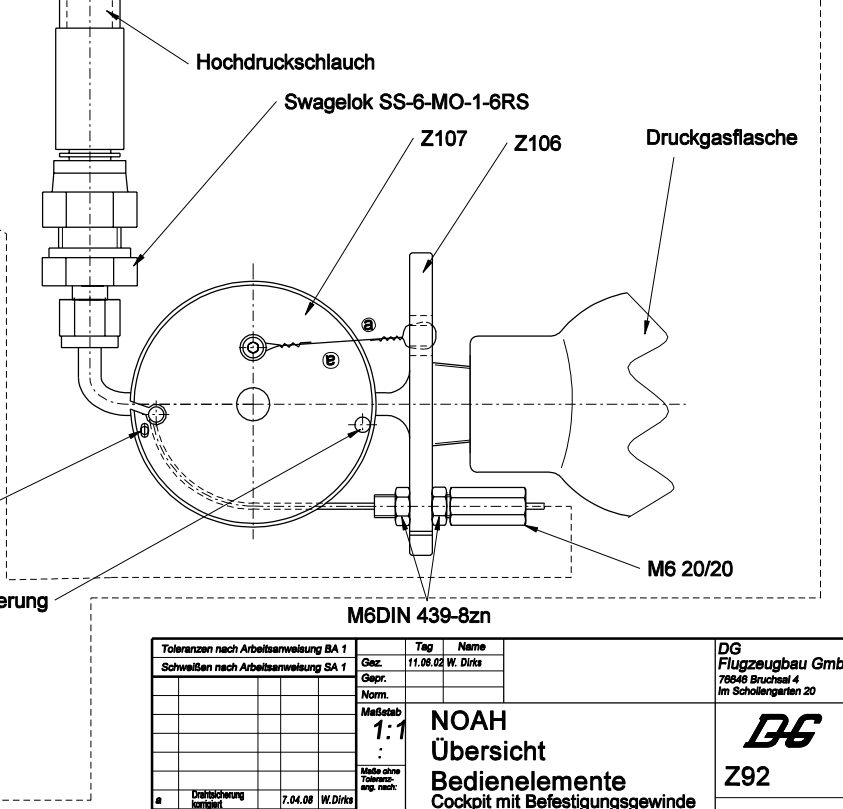
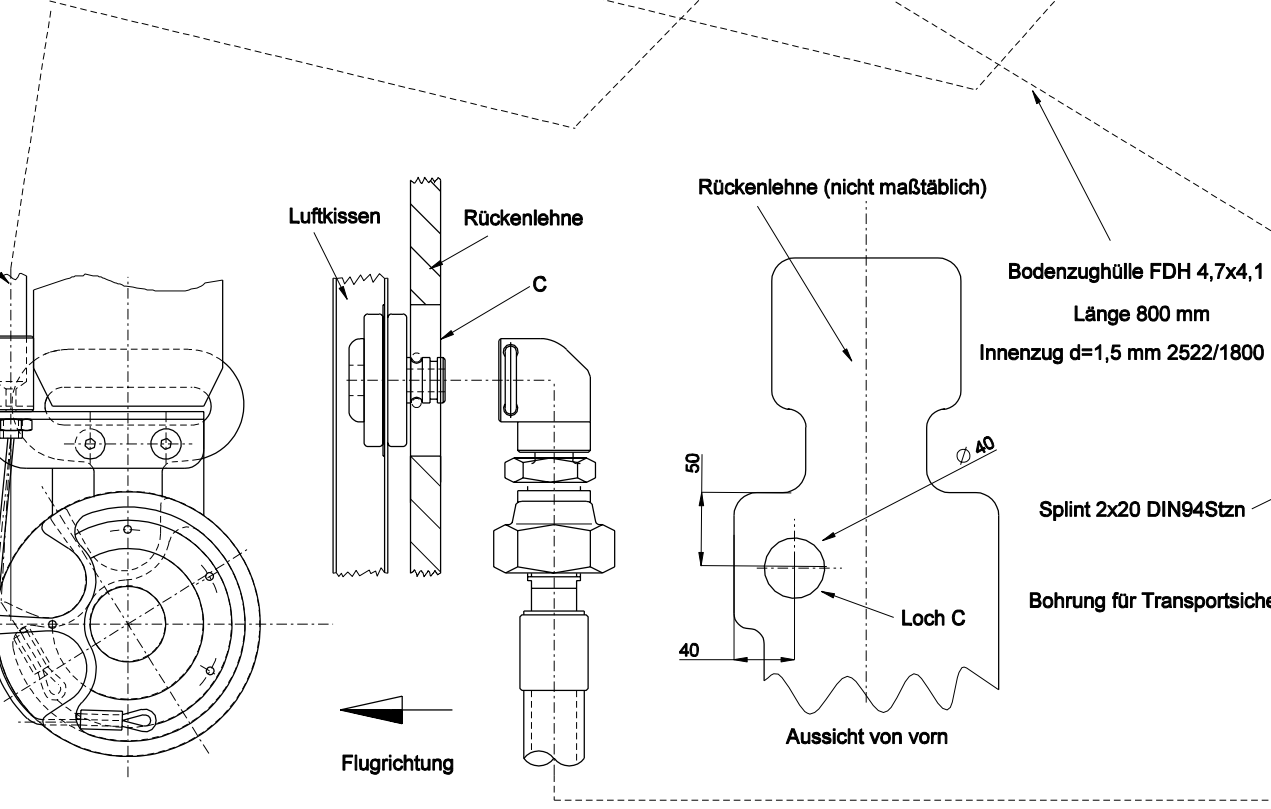
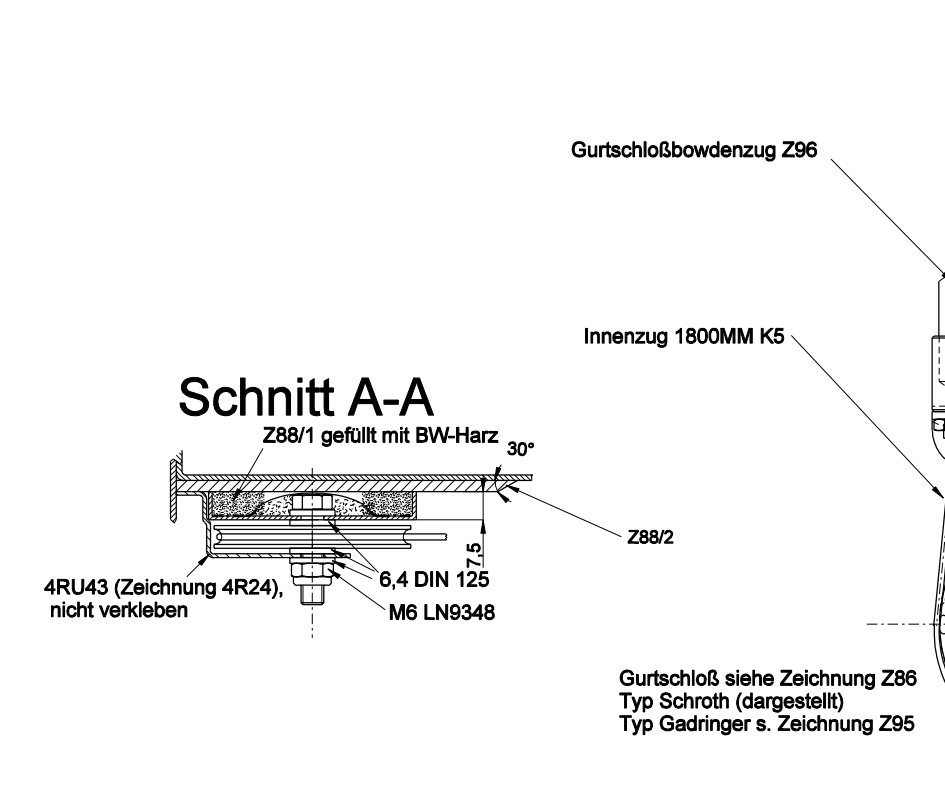
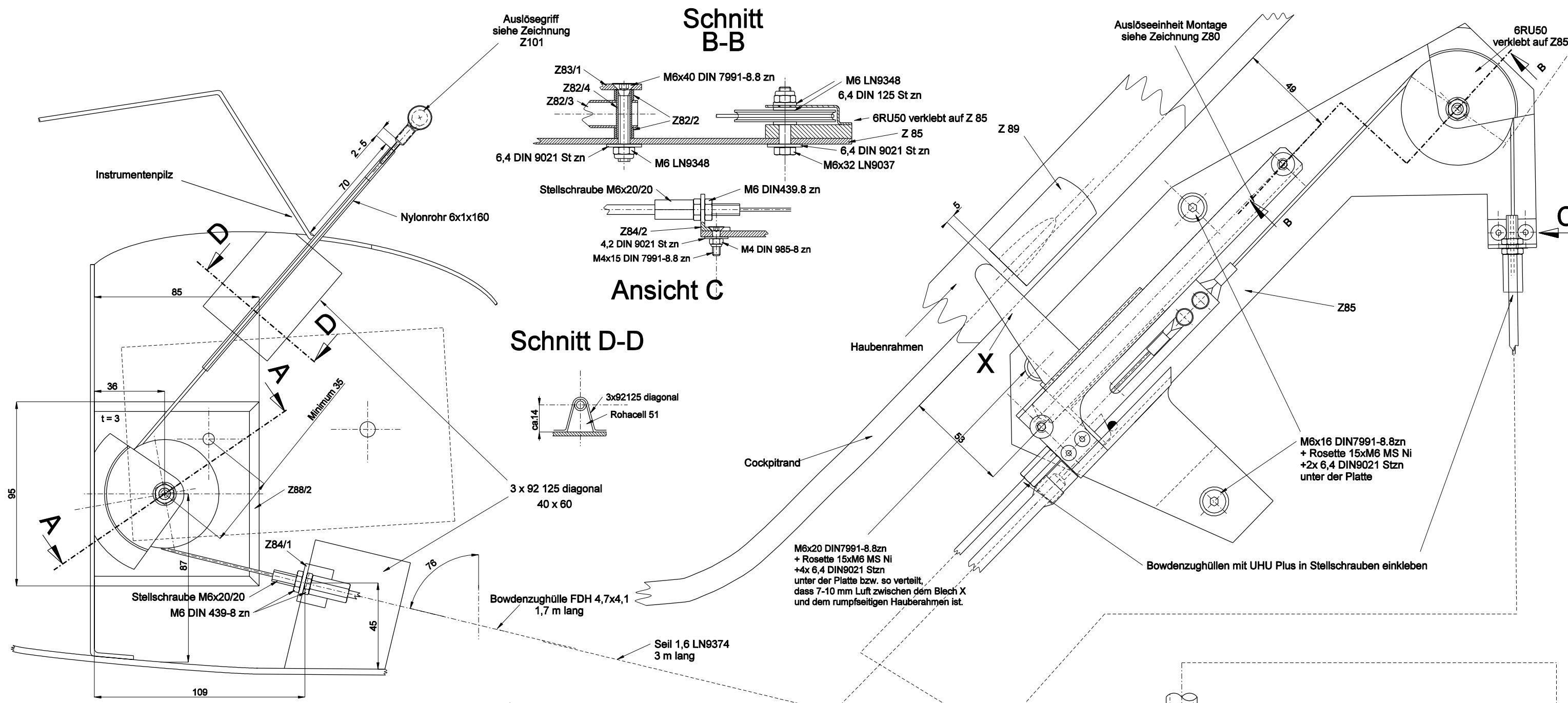

Toleranzen nach Arbeitsanweisung BA 1				Gez.	Tag	Name
Schweißen nach Arbeitsanweisung SA 1				11.08.02	W. Dirks	
Norm.						
Maßstab				1:1		
Maße ohne Toleranzangabe						
a	Erstzeichnung	7.04.08	W. Dirks			
Ausg.	Änderung	AM	Tag	Name		

NOAH Übersicht Bedienelemente Cockpit mit Befestigungsgewinde an rechter Seitenwand

DG Flugzeugbau GmbH
 78646 Bruchsal 4
 Im Schöllengarten 20

GG

Z92

Abdeckung

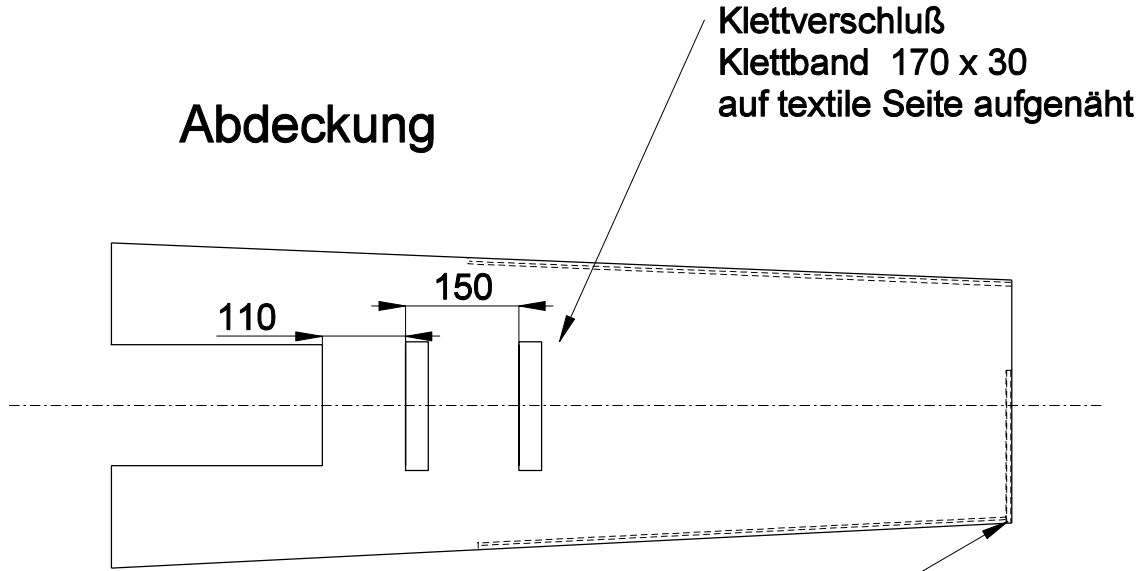

Klettverschluß
Flauschband 180 x 16
auf beschichteter Seite aufgenäht

Faltlinien

NOAH Kissen

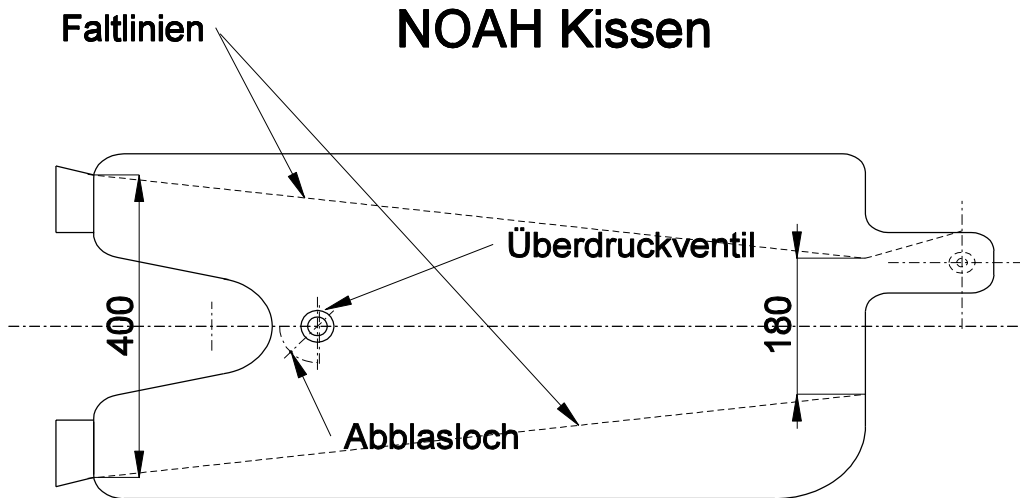

Kissen kann nach oben oder nach unten gefaltet werden

Toleranzen nach Arbeitsanweisung BA 1					Tag	Name	DG Flugzeugbau GmbH 76646 Bruchsal 4 Im Schollengarten 20
Schweißen nach Arbeitsanweisung SA 1					Gez.	20.06.02 W. Dirks	
					Gepr.		
					Norm.		
					Maßstab	NOAH Faltanweisung für Kissen, Abdeckung	 Z99
					.		
					.		
					Maße ohne Toleranzang. nach:		
a	NOAH-Kissen bearb.	12.02.03	K.Thiel				
Ausg.	Änderung	ÄM	Tag	Name			

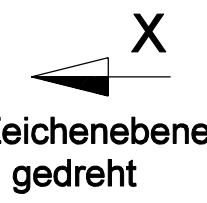
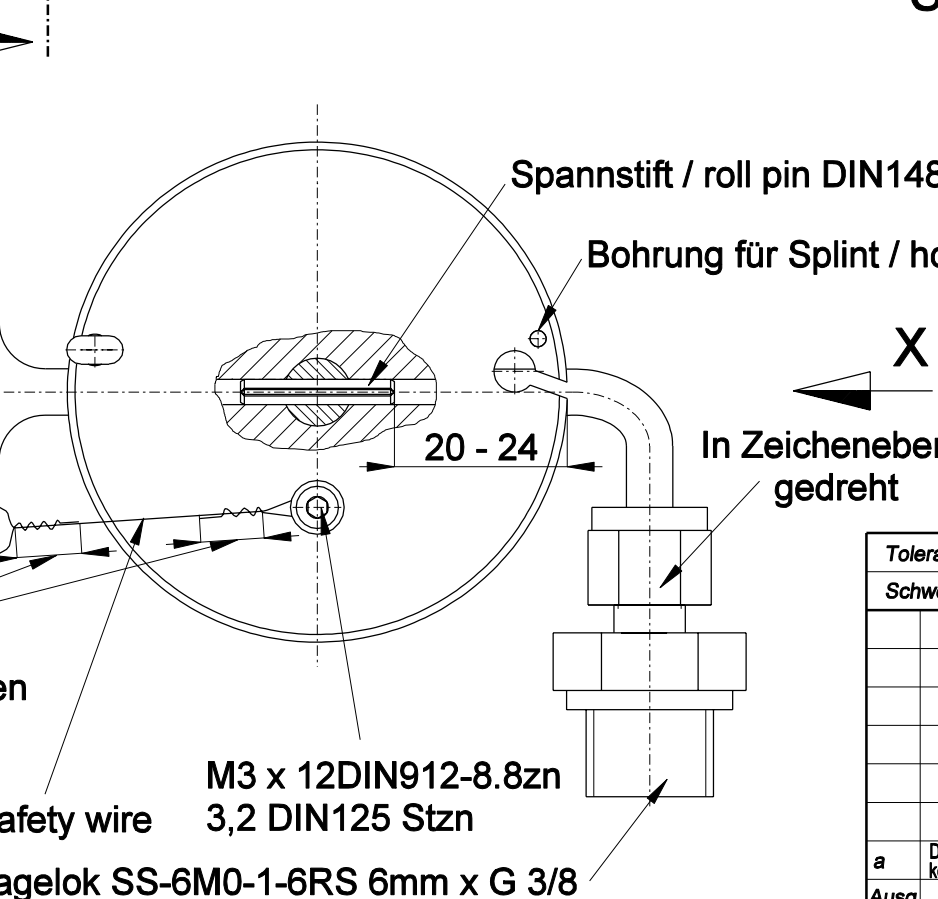
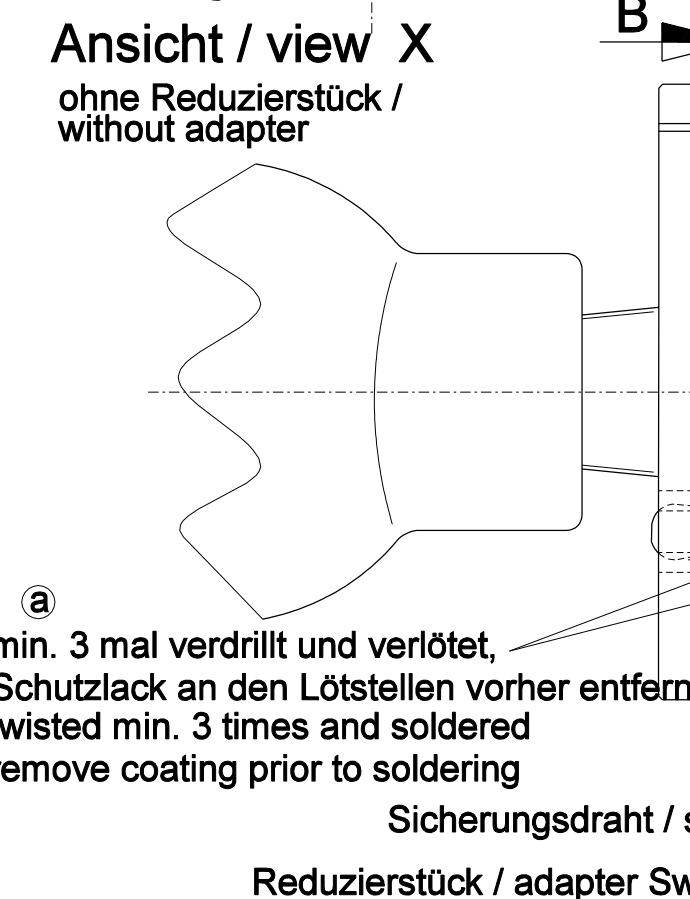
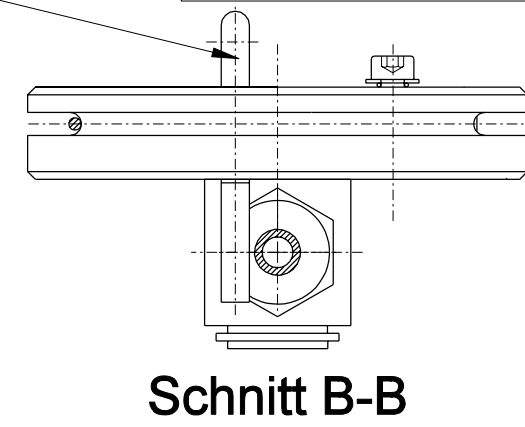
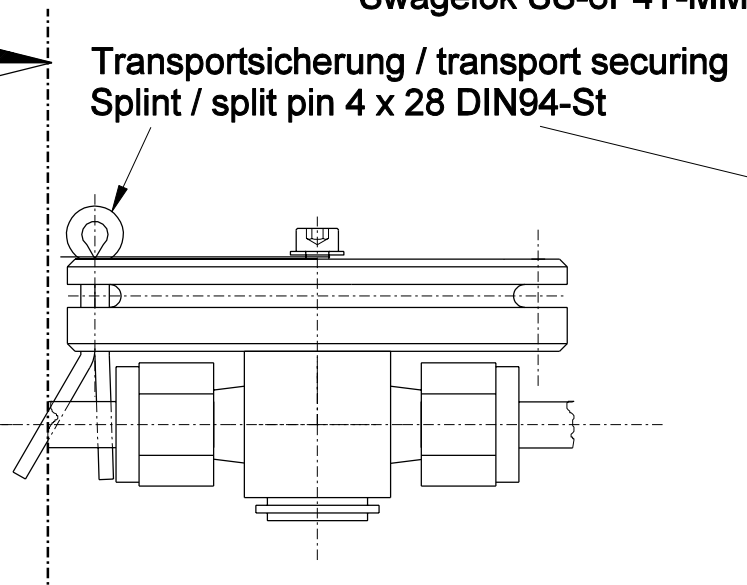
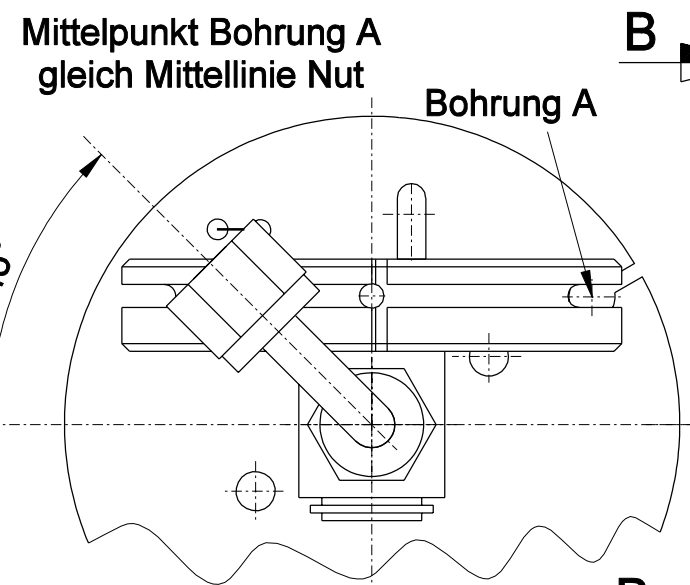
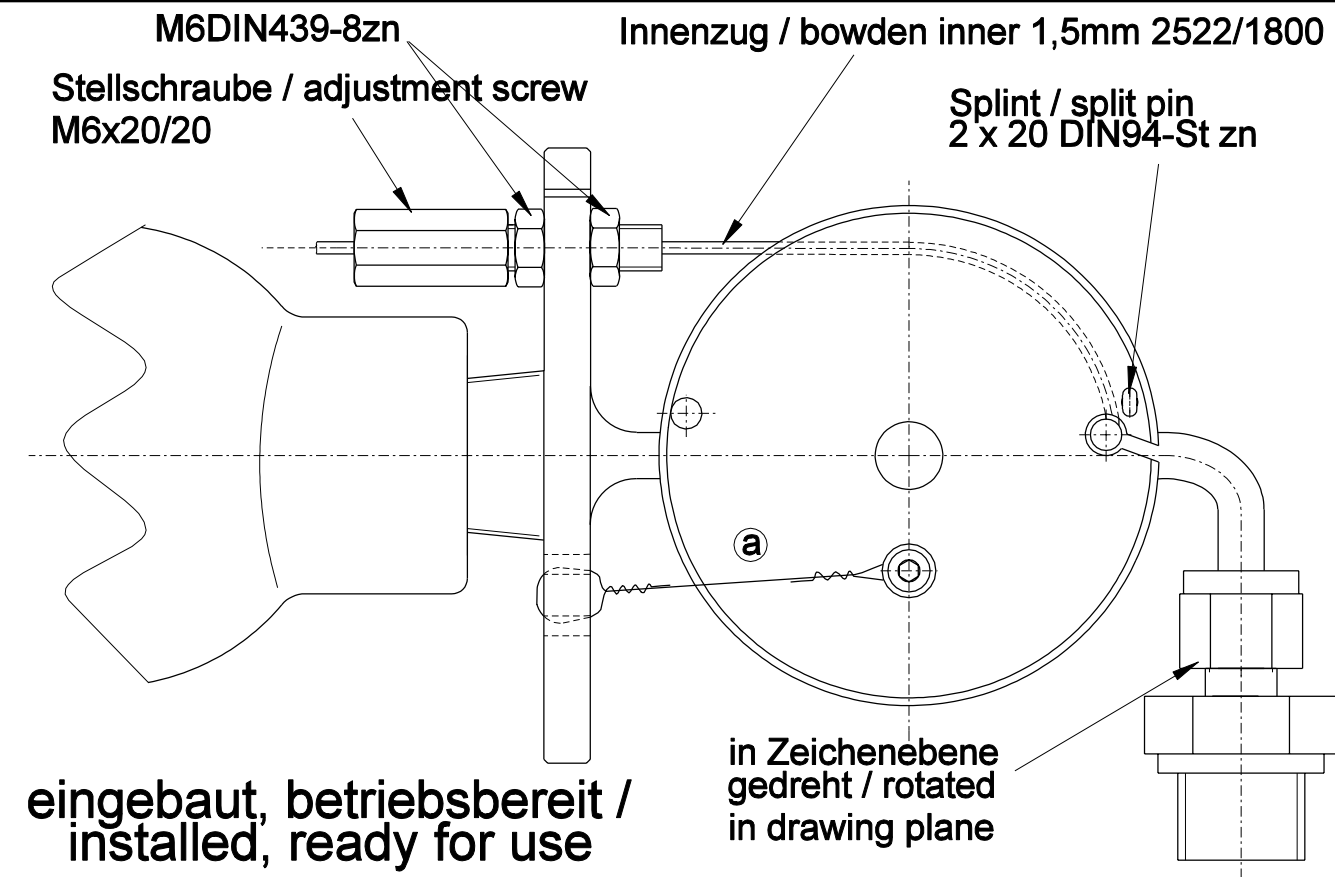
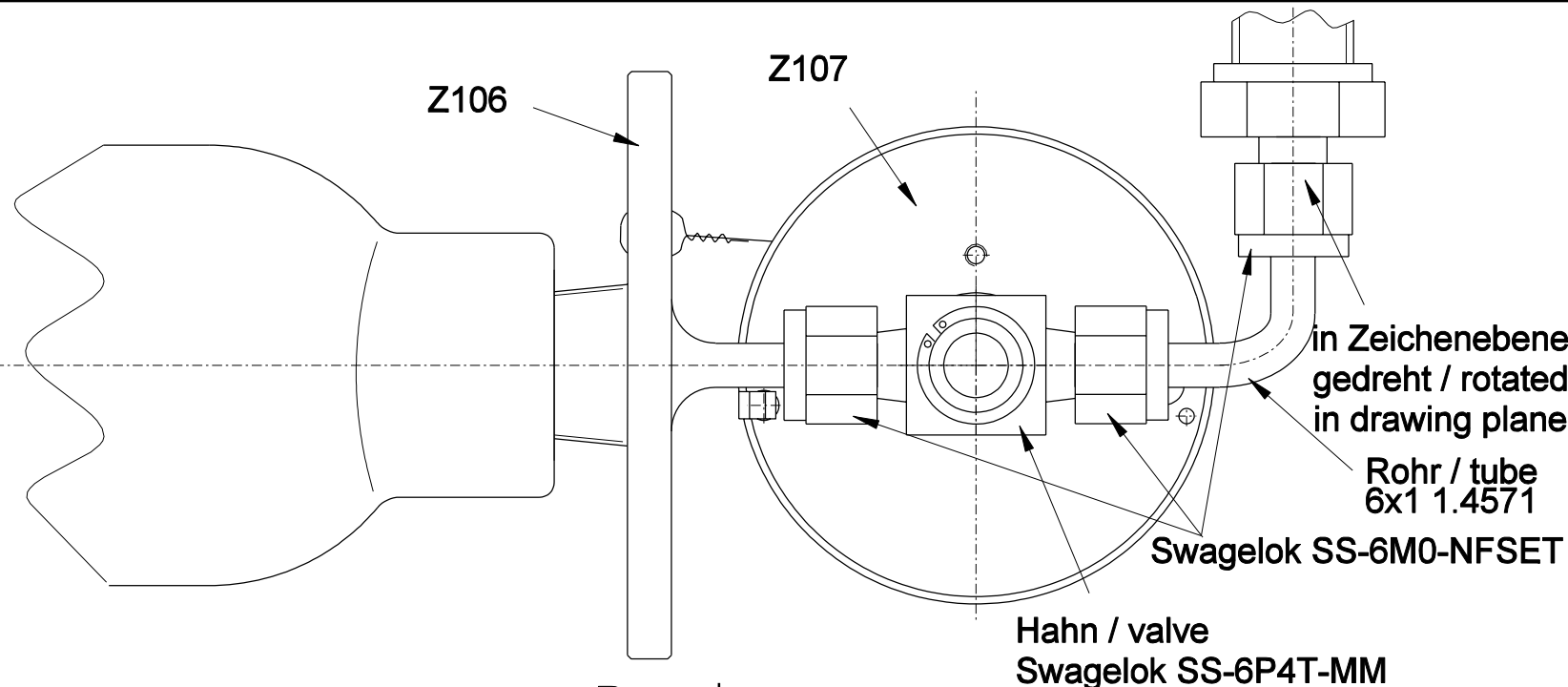

pressurised gas cylinder assembly with securing system

min. 3 mal verdreht und verlötet, Schutzlack an den Lötstellen vorher entfernen
twisted min. 3 times and soldered remove coating prior to soldering

Toleranzen nach Arbeitsanweisung BA 1		Tag	Name
Schweißen nach Arbeitsanweisung SA 1		Gez.	11.06.02 R. Kern
		Gepr.	
		Norm.	
		Maßstab	1:1
			:
		Maße ohne Toleranzang. nach:	
a	Drahtsicherung korrigiert	3.04.08	W. Dirks
Ausg.	Änderung	ÄM	Tag Name

<p>Zusammenbau Druckgasflasche und Hahn mit Sicherung</p>		<p>DG Flugzeugbau GmbH 76646 Bruchsal 4 Im Schollengarten 20</p>  <p>Z108</p>
<p>Maße ohne Toleranzang. nach:</p>		

Refilling instructions

1. General

The pressurised gas cylinder should only be filled with water free nitrogen. If nitrogen is not available filling with dry- air is acceptable. A dry medium is essential to avoid icing during flights at high altitude, or temperatures below freezing.)

For refilling and inspecting a NOAH pressurised gas cylinder the following appliances are necessary.

1. Refilling station or large pressurised gas cylinder with min 220 bar (15.18 psi) pressure.
2. Adapter for the thread at the NOAH unit which is a cylindrical thread G 3/8.
3. Manometer (pressure gauge) measuring range up to 250 bar (17.05 psi).
4. Digital scale with 0,1g resolution.

2. Refilling

The Manometer should be installed between the valve at the NOAH pressurised gas cylinder and a second shut off valve in the line to the filling station.

After connecting the lines remove the screw which is fixing the safety wire to the disc on the valve and slowly open the valves at the NOAH unit and to the refilling station.

Fill up to 215 bar (14.84 psi). Close the valve to the refilling station.

At standard atmospheric pressure, the pressure in the NOAH pressurised gas cylinder must be 200 bar (13.8 psi).

During refilling the nitrogen or compressed air will raise its temperature and thus a higher filling pressure is needed.

After the NOAH pressurised gas cylinder has cooled down the pressure must be checked and further refilling to 200 bar may be necessary.

Out of experience a pressure of 215 bar is sufficient to reach 200 bar after cooling down.

Close the valve of the NOAH pressurised gas cylinder.

Remove the NOAH unit from the refilling station.

Weigh the NOAH pressurised gas cylinder and enter the weight into the placard on the cylinder.

3. Inspection after refilling

Leak test: Hold the NOAH unit with the valve down into still water (no air bubbles) which should be in a transparent container. The cylinder should be in the water up to its shoulder to detect any possible leaks.

Check for min. 5 minutes under water, in order to detect the slightest leaks. No leaks are permissible.

The weight of the NOAH pressurised gas cylinder must be rechecked after 2 weeks storage to detect very small leaks. The max. permissible weight reduction is 0.5 g.

4. **Sealing leaks**

Possible areas where leaks may occur:

- screwed joint of the valve to the flange of the NOAH pressurised gas cylinder Z106
- The valve
- screwed joint of the flange Z106 to the cylinder

If there is a leak at the screwed joint of the flange Z106 to the cylinder the cylinder must be emptied by slightly unscrewing the flange. Sealant “Hylomar” (a blue sealant used by Rolls-Royce produced under license by MARSTON Oelchemie) should be applied to the thread of the flange. Screw in the flange after 5 minutes curing time.

If the valve leaks it must be exchanged.

5. **Securing the valve of the NOAH pressurised gas cylinder**

The valve must be secured against inadvertent opening with safety wire according to the sketch below.

If the safety wire is still undamaged, reinstall the screw which is fixing the safety wire to the disc on the valve together with the safety wire. Secure the screw with red securing paint.

Otherwise a new safety wire must be installed. Only the prefabricated safety wire DG part no. 10180843 is approved and must be obtained from DG Flugzeugbau.

Other safety wire may make the opening of the NOAH pressurised gas cylinder by the pilot impossible.

